



# Mercedes College

## Trial WACE Examination 2014

### PHYSICS

### Stage 3

Write your name here

#### Time allowed for this paper

Reading time before commencing work: ten minutes  
Working time for paper: three hours

#### Materials required/recommended for this paper

##### *To be provided by the supervisor*

This Question/Answer Booklet  
Formulae and Constants Sheet

##### *To be provided by the candidate*

Standard items: pens, pencils, eraser, correction fluid, ruler, highlighters

Special items: non-programmable calculators satisfying the conditions set by SCSA for this course.  
Graphics calculators may **not** be used.

#### Important note to candidates

No other items may be taken into the examination room. It is **your** responsibility to ensure that you do not have any unauthorised notes or other items of a non-personal nature in the examination room. If you have any unauthorised material with you, hand it to the supervisor **before** reading any further.

#### MARKS SUMMARY

Section One (60 marks = 30%)	Section Two (100 marks= 50%)	Section Three (40 marks= 20%)	Total Mark (200)	Final %

## Structure of this paper

Section	Number of questions available	Number of questions to be answered	Suggested working time (minutes)	Marks available	Percentage of exam
Section One: Short answers	16	16	60	60	30
Section Two: Extended Answer	7	7	80	100	50
Section Three: Comprehension and Data Analysis	2	2	40	40	20
					100

## Instructions to candidates

1. The rules for the conduct of Western Australian external examinations are detailed in the *Year 12 Information Handbook 2014*. Sitting this examination implies that you agree to abide by these rules.
2. Write your answers in this Question/Answer Booklet. Use blue or black biro.
3. Working or reasoning should be clearly shown when calculating or estimating answers.
4. You must be careful to confine your responses to the specific questions asked and to follow any instructions that are specific to a particular question.
5. The "Formula and Constants Sheet" may be used as required.
6. All final numerical answers should be expressed to **three** (3) significant figures and include the appropriate **units**.

**SECTION ONE** (Short Answer – worth 60 marks or 30 % of total for paper)

This section contains **16** questions. Answer **all** questions in the space provided below the question.

**Question 1**

This diagram shows the path of a cannonball, fired from a cannon.

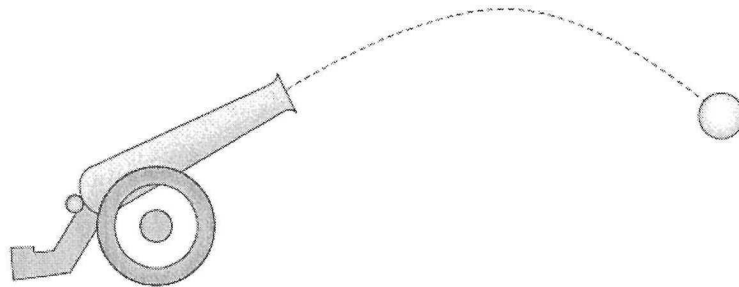

Which set of vectors represents the horizontal and vertical components of the cannonball's velocity along the path?

	<i>Horizontal</i>				<i>Vertical</i>			
(A)	→	→	→	→	↓	↓	↓	↓
(B)	→	→	→	→	↑	↑	↓	↓
(C)	→	→	→	→	↑	↑	↓	↓
(D)	→	→	→	→	↓	↓	↓	↓



Briefly justify your answer.

**[3 marks]**

**Question 2**

A mass of 2.0 kg is being swung by a light rod in a vertical circle of radius 1.0 m at a constant speed of  $7.0 \text{ ms}^{-1}$ , as shown in the diagram below.

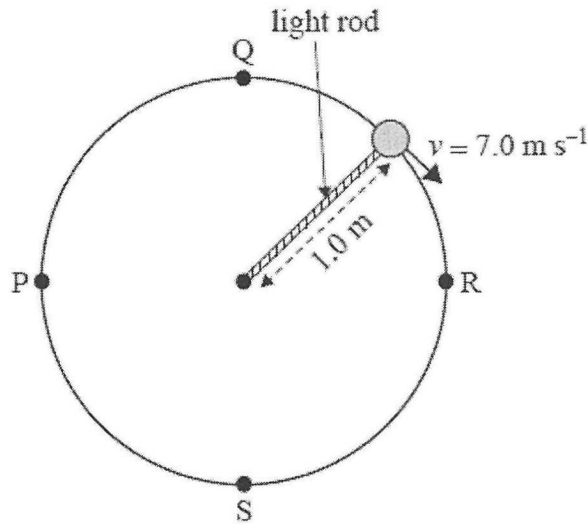

- a) Which of the directions (A-F) below shows the direction of the net force on the mass when it is at point P?

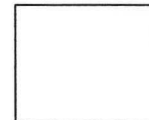
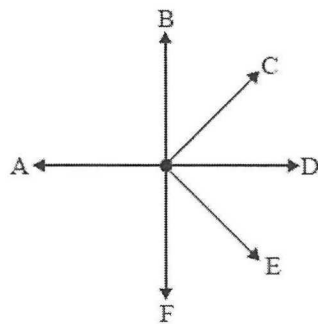

[1 mark]

- b) Calculate the magnitude of the tension in the light rod when it is at point S.

[2 marks]



**Question 3**

Engineers are designing a curve on a high-speed railway track. To prevent excessive wear and for the comfort of the passengers, it is important that the track be correctly banked so that there are no sideways forces between the rail and the wheel of the train. This is shown in the diagram below.

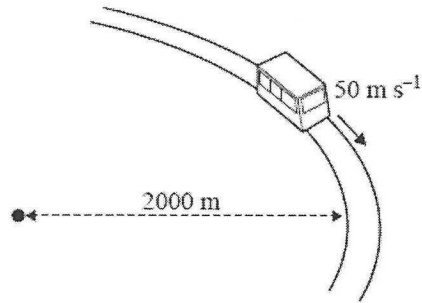

The radius of the curve is  $2000 \text{ m}$  and the speed of the train is a constant  $50 \text{ m s}^{-1}$ .

- a) On the diagram below, draw two arrows to show external forces acting on the train and a third arrow, marked as  $F_{\text{NET}}$  to show the net force acting on the train.

[2 marks]

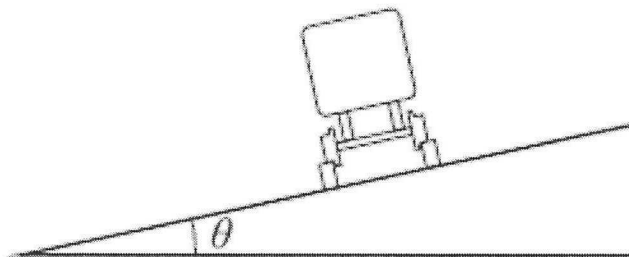

- b) Calculate the correct angle of bank ( $\theta$ ) for the track to the horizontal for there to be no sideways forces on the wheels by the track.

[2 marks]

**Question 4**

Two solenoids are shown in the diagram below. Current is flowing through their coils and both of them are generating magnetic fields. Their combined field is much greater than the Earth's field.

Draw at least four flux lines in the space enclosed by the dashed rectangle. Mark the direction of each flux line you draw.

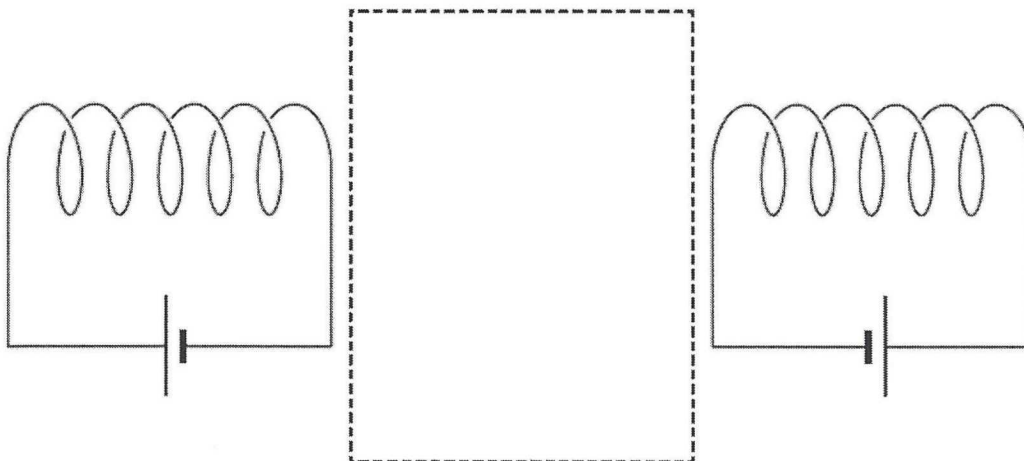
**[3 marks]****Question 5**

A distant star has a mass equivalent to that of 6 Suns and is approximately 8.55 light years from the Earth. What is the gravitational force between the star and the Earth?

$$1 \text{ light year} = 9.46 \times 10^{12} \text{ km}$$

**[4 marks]**

**Question 6**

The spaceship Andromeda (A) is travelling at  $0.7c$  towards the asteroid Ceres (C). It sends a pulse of light to the nearby spaceship Bradbury (B), which is approaching the asteroid from the far side at  $0.8c$ , as shown below.

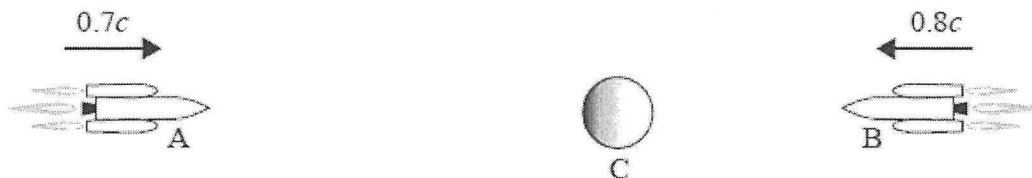

Which of the following statements is correct?

The speed of the light pulse as measured from each body is

- 1- Greatest for A and least for B
- 2- Greatest for B and least for A
- 3- Greatest for C and least for B
- 4- The same for each body

[2 marks]

Justify your answer.

---



---



---



---



---



---

Lucy is on a train travelling at  $0.8c$ . The train passes Grace, who is standing on the platform at a train station. They each measure a different length for the train and also measure a different length for the platform.

Use the words "Longer", "Proper" or "Shorter" to describe how each observer will measure the length of the train and the length of the platform.

Measurement	Lucy	Grace
Length of the train		
Length of the platform		

[2 marks]



**Question 8**

A teacher asks a student to identify a gas contained in a tube by measuring the speed of sound. The student connects a signal generator to a loudspeaker and a microphone is moved away from the speaker (to the right of the page) until a minimum (node) is displayed on the oscilloscope. The tube is closed at one end.

At a frequency of 500 Hz, the student finds the distance between two adjacent nodes to be 0.96 m.

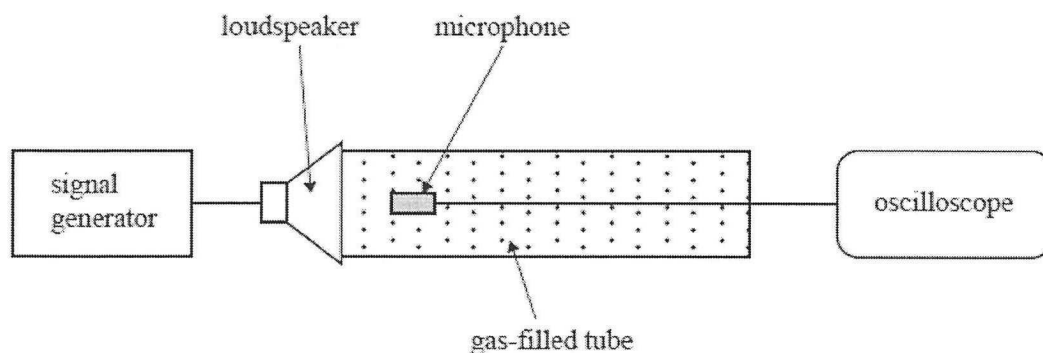

The student uses the Internet to find the speed of sound in a range of different gases. Her finds are shown below:

Gas	Carbon dioxide	Helium	Hydrogen	Oxygen
Speed of sound (ms <sup>-1</sup> )	286	962	1270	366

With an appropriate calculation, identify the gas used inside the tube.

**[3 marks]**

**Question 9**

In a nuclear power station liquid sodium is used to cool parts of the reactor. An electromagnetic pump keeps the coolant circulating.

The sodium enters a perpendicular magnetic field and an electric current, ( $I$ ), passes through it. A force is experienced by the sodium that causes it to flow in the direction as shown in the diagram below.

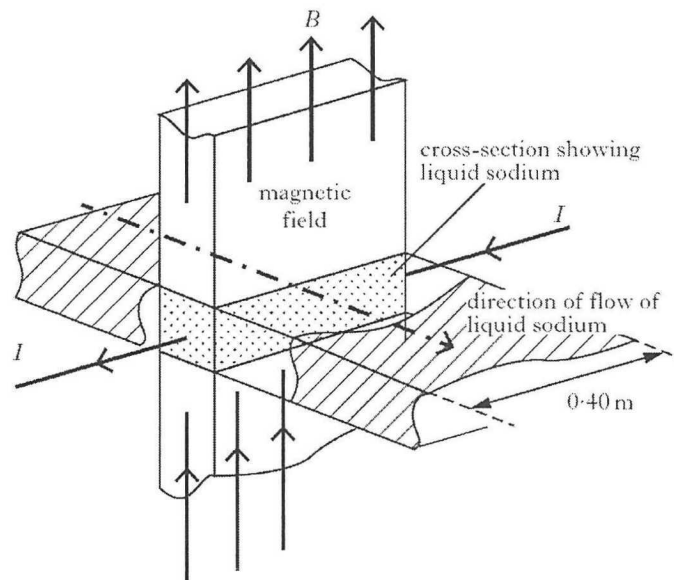

The magnetic field strength is 0.225 T. The current ( $I$ ) in the sodium is 2.53 A, and is perpendicular to the magnetic field.

- a) Calculate the force acting on the 0.40 m length of sodium within the magnetic field.

[2 marks]

- b) The pump is moved during maintenance and as a result the direction of the magnetic field is changed so that it is no longer perpendicular to the current. What effect does this have on the rate of flow of sodium passing through the pump? **You must justify your answer.**

[2 marks]

**Question 10**

An experiment is carried out using microwaves of wavelength 30 mm. The microwaves pass through two gaps between metal plates as shown.

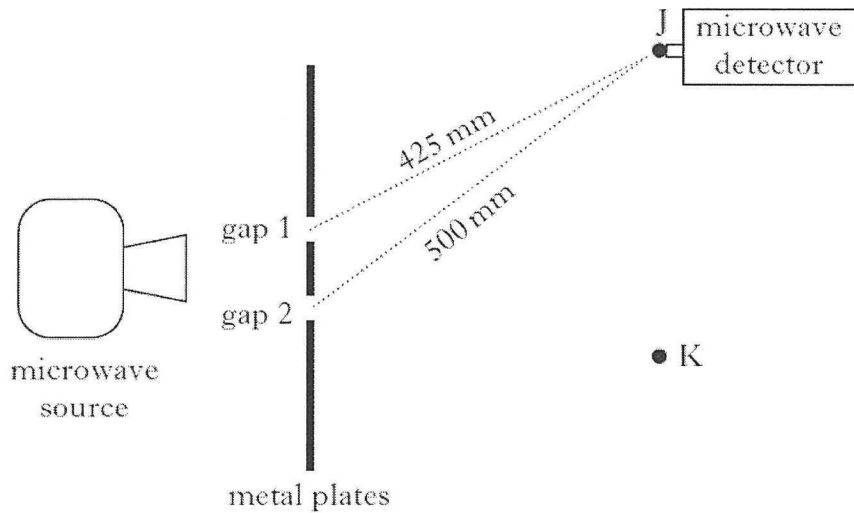

The distances from each of the gaps to point J are shown in the diagram.

- a) Use this information to determine whether point J is a point of constructive or destructive interference. Justify your answer with an appropriate calculation.

[3 marks]

- b) The microwave detector is now moved to K, which is a point of destructive interference. Gap 1 is then covered with a sheet of metal.

Does the strength of the signal at K increase, decrease or stay the same? **Explain your answer.**

[2 marks]



**Question 11**

A metre rule of mass 55 g is held horizontal by two spring balances, and has a 120 g mass attached at the 5 cm mark as shown.

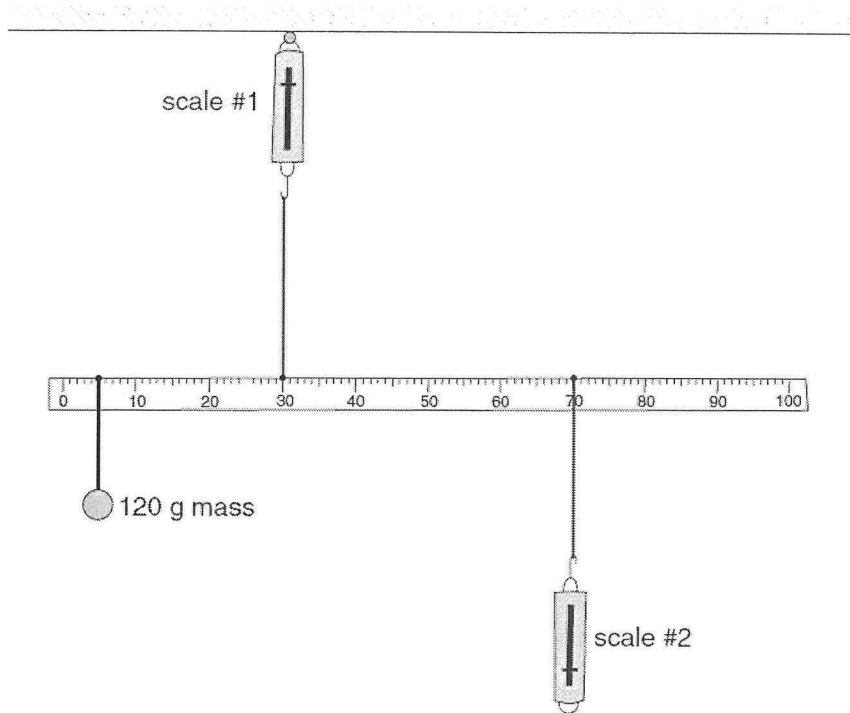

What is the reading on scale # 1?

[4 marks]

**Question 12**

Rumisha is filling an empty bottle with water from the tap. She notices that as the water strikes the inside of the bottle, it makes a sound which increases in pitch as the bottle fills.

- Name the physics phenomenon responsible for the sound produced in the bottle.
- Explain why the pitch (frequency) increases as the bottle fills.

[3 marks]

**Question 13**

A solid aluminium rod is made to roll down a frictionless slope as shown in the diagram below.

Show on the diagram the **direction** of a uniform magnetic field that would produce **both** of the following:

- ♥ The maximum induced EMF
- ♥ End A of the rod being positive

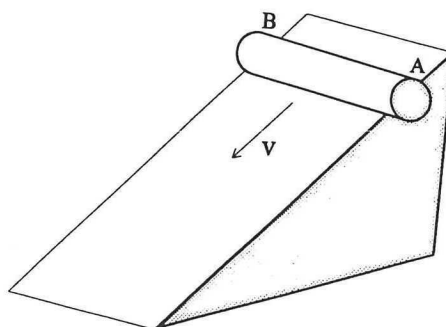

[2 marks]

**Question 14**

Quarks are the fundamental particles of which hadrons are composed. The table below shows the properties of some quarks.

Type of Quark	Symbol	Charge (in terms of $e^-$ )
Up	u	+2/3
Down	d	-1/3
Strange	s	-1/3

- a) Rho-minus mesons are sub-atomic particles that consist of an anti-up quark and a down quark. Determine the charge for a rho-minus meson.

[1 mark]

- b) What is the charge for a baryon that consists of an up, a down and an anti-strange quark?

[1 mark]

**Question 15**

The diagrams below show the absorption spectrum for a particular element found in many galaxies.

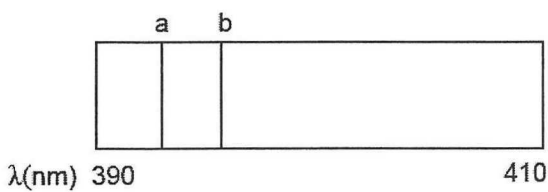

Absorption spectrum of the element as measured and observed on Earth

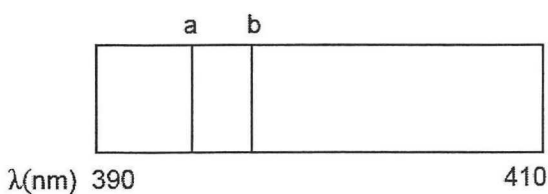

Absorption spectrum of the element in the light from galaxy NGC 2189

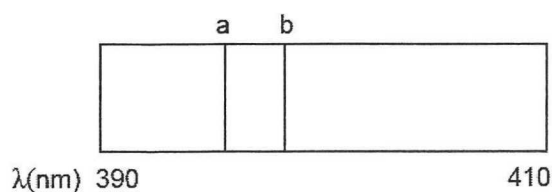

Absorption spectrum of the element in the light from galaxy NGC 3034

- a) Are the two galaxies moving towards the Earth or away from the Earth? Give reasons to support your answer.

Which of the galaxies is moving with the greater velocity? \_\_\_\_\_

[2 marks]

- b) Calculate the distance from the Earth, in **light years**, of a galaxy moving with a recessional velocity of  $0.66c$ , where “c” is the speed of light in empty space.

Hubble’s Law states:  $v = H_0 \times d$

Take the Hubble constant  $H_0 = 71 \text{ kms}^{-1} \text{ Mpc}^{-1}$

The conversion factor is  $1 \text{ Mpc} = 3.26 \times 10^6 \text{ light years}$

[3 marks]

**Question 16**

Formula 1 racing cars have a wing above the rear wheels that causes a downward force to aid traction. The wings are often made from graphite, a form of carbon that is a conductor. The wing, is however, electrically insulated from the rest of the car.

A car with a 2.25 m wing is travelling south at  $228 \text{ kmh}^{-1}$ .



Albert Park is the site of the Melbourne Grand Prix. At this location the Earth's magnetic field has strength of  $61.7 \mu\text{T}$  and an angle of dip equal to  $71^\circ$ .

- a) Determine the magnitude and direction of the **vertical** component of the Earth's magnetic field near Albert Park.

[2 marks]

- b) What is the magnitude of the EMF that will be generated between the tips of the wing?

[2 marks]

**Question 17**

The table below shows the energy released from some metals when they are bombarded with high speed electrons in an X-ray tube.

Metal	Energy release (keV)
Molybdenum	7.96
Tungsten	9.48
Metal A	0.03

- a) The bombarding electrons have energy of around 50 keV yet the table shows only a small portion of this energy is actually released as X-ray photons by atoms in the target metal. What happens to the rest of the energy?

---



---



---

[1 mark]

The graph shown is a typical X-ray spectrum for a target atom in an X-ray tube.

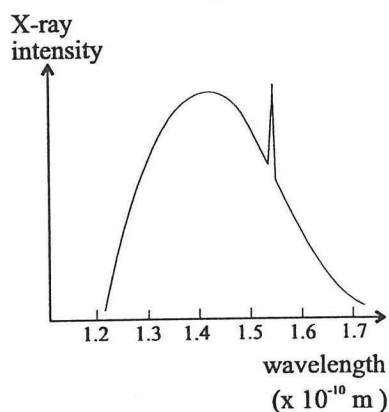

- b) Which metal listed in the table above corresponds to the peak shown in the graph? Justify your answer.

[3 marks]

End of Section One

**SECTION TWO:** (Problem Solving – worth 100 marks or 50 % of total for paper)

This section contains **SEVEN** (7) questions. Answer all questions in the spaces provided.

**Question 18**

In March 1999, the Mars Global Surveyor entered its final circular orbit around Mars. From there it transmitted information about Mars back to Earth that aided later missions such as the Curiosity Rover.

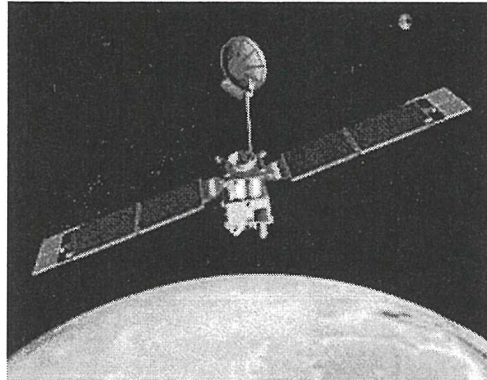

Mass of Global Surveyor	930 kg
Radius of orbit of Global Surveyor	$3.83 \times 10^6$ m
Period of orbit of Global Surveyor	120 minutes
Radius of Mars	3395 km

- a) Use this data to determine the mass of Mars.

**[4 marks]**



- b) If an orbiting satellite of twice the mass of Global Surveyor had been used, what would its period of orbit have been? Justify your answer.

[3 marks]

- c) Determine the acceleration due to gravity on the surface of Mars and hence find the weight of an 800 kg Curiosity Rover when it landed on the surface of Mars 13 years later.

[4 marks]

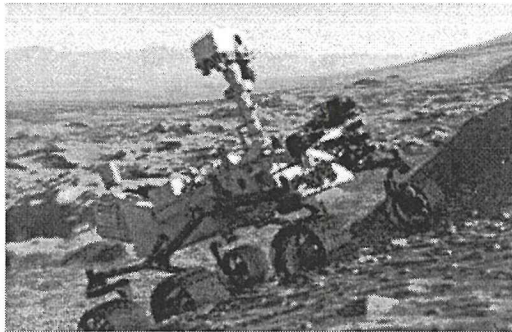

Question 19

A diagram of a DC motor is shown below.

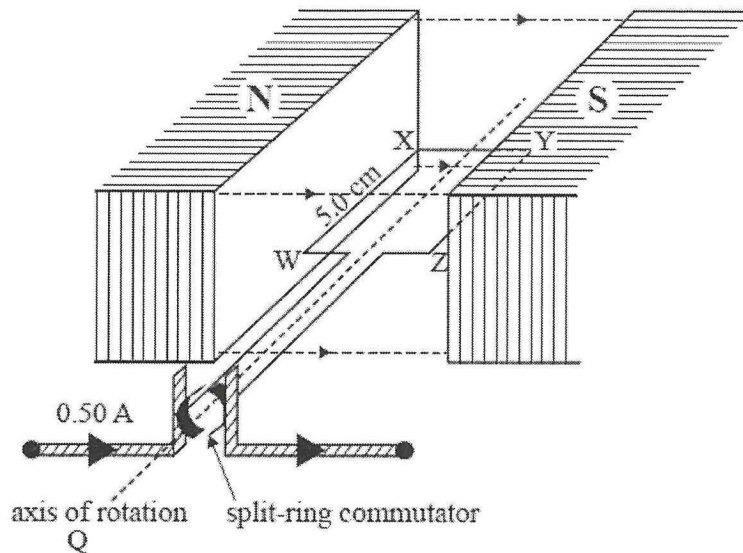

- a) The motor is operating and the rectangular coil is rotating about the axis of rotation. Amy views the operating motor from point **Q**.

Is the direction of rotation clockwise or anticlockwise? Give a reason for your answer.

[2 marks]

- b) While in the position shown in the diagram, a current of 0.50 A is flowing in the rotating coil. The coil has 20 turns and the magnetic field at the side labelled **WX** has strength of 620 mT. The side **WX** has a length of 5.0 cm and side **XY** has a length of 3.8 cm

Calculate the magnitude of the force on the side **WX**.

[2 marks]



- d) There is a split-ring commutator fitted to the motor. Amy suggests that the split-ring commutator causes a lot of friction on the motor, and that the motor would rotate faster if the split-ring commutator were removed and, instead, slip-rings were used to connect the input DC current to the rotating coil.

Would this change improve the operation of the motor? Give reasons for your answer.

---

---

---

---

---

---

---

---

[3 marks]

**Question 20**

To produce electrical energy for bicycles a small generator can be attached to the front fork of the bicycle frame. The rotating wheels of the bicycle wheel turn a rotor on the generator that in turn spins an armature coil within the generator.

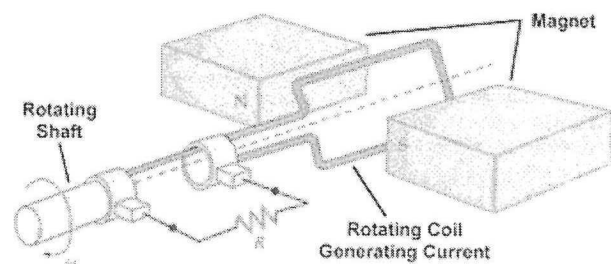

- a) What are two ways of improving the ability of the generator to produce electricity?

[2 marks]

---

---

---

- b) A particular bicycle generator has a square coil of sides 1.80 cm and 900 turns. The magnetic field used is 0.250 T and the average EMF produced is 2.80 V. At how many revolutions per second must the coil rotate to produce this average voltage output?

[5 marks]

- c) Many cyclists actually choose battery-powered lights over the type of generator shown. Give **two** reasons based on **physics concepts** why they may choose battery power.

[2 marks]

---



---



---

The following is a description of another way of generating an electric current.

An aluminium ring is made to oscillate vertically between point A and point B.

Point C is the midpoint between A and B.

A strong, small magnet is fixed at the centre of the oscillation as shown.

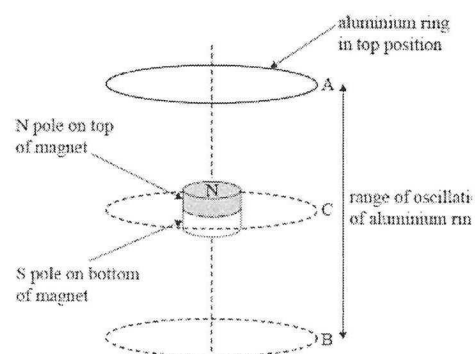

The vertical dashed line goes through the centre of the aluminium ring and also through the centre of the bar magnet in the diagram.

The magnetic flux through the aluminium ring is graphed as a function of time in the graph shown below.

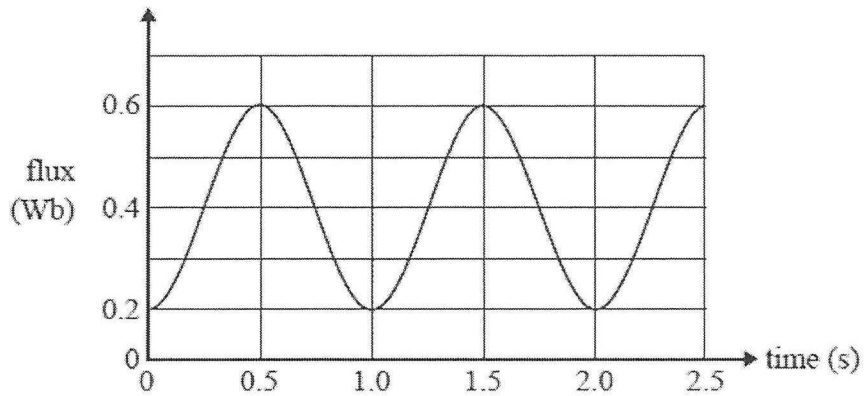

- d) The resistance measured around the ring is 0.15 ohm. Calculate the (average) current induced in the ring from time  $t = 1.0$  seconds to  $t = 1.5$  seconds.

[3 marks]

- e) When the ring is moving **downwards** towards the N pole of the magnet, a current flows around the ring. Use a sketch or words to describe the direction of this induced current when viewed from **above**. Explain your answer carefully.

[3 marks]

**Question 21**

The colour of many corals is due to fluorescent corals. Stony coral contains the protein P-620, and when exposed to ultraviolet light, it glows with a particularly bright colour. People with aquariums that contain living coral use special lamps that emit UV light to ensure that the coral is always coloured.

a) Briefly describe how fluorescence occurs.

---

---

---

---

---

---

---

---

---

---

---

**[3 marks]**

A partial energy level diagram for P-620 is shown below.

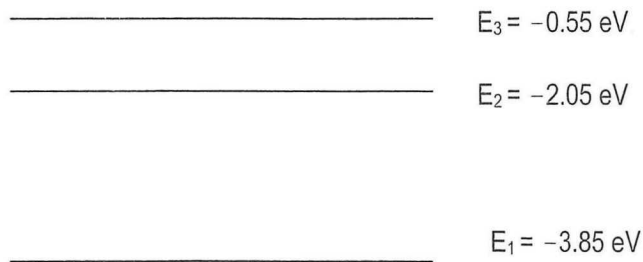

b) Calculate the **wavelength** of the UV light needed to cause fluorescence in P-620.

**[3 marks]**



- c) Calculate the wavelength of the emission line with the **shorter** wavelength and hence determine the **colour** of stony coral under UV light.

[4 marks]

<i>colour</i>	<i>wavelength (nm)</i>
red	700
orange	620
yellow	560
green	515
blue	470
indigo	440
violet	410

- d) Many of the UV lamps sold to aquarium owners have acrylic-coated safety covers, designed to shield people from the more dangerous forms of UV radiation. Why is UV radiation considered harmful to humans?

---

---

---

---

---

---

---

[2 marks]

The following graph shows the transmission properties of an acrylic-coated safety cover. At least 50 % transmission is needed for enough UV light to illuminate the coral in an aquarium.

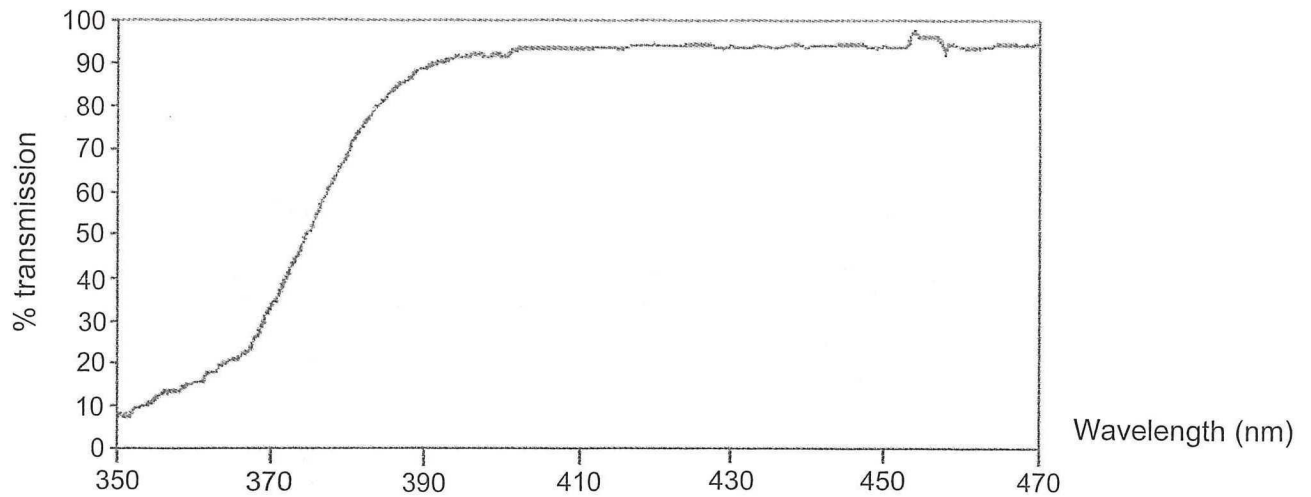

- e) Determine the percentage transmission of the particular UV light that can cause stony coral to fluoresce (as determined in b) above) and hence explain whether or not this material would be a suitable cover for an aquarium lamp if the owner wanted stony coral to fluoresce.

[3 marks]

See next page

**Question 22**

In a badminton match, players hit a shuttlecock over a net so that it will land inside of a court. The total length of the court is 13.4 m.

By design, air resistance has a greater effect on the movement of a shuttlecock than it would on most projectiles.

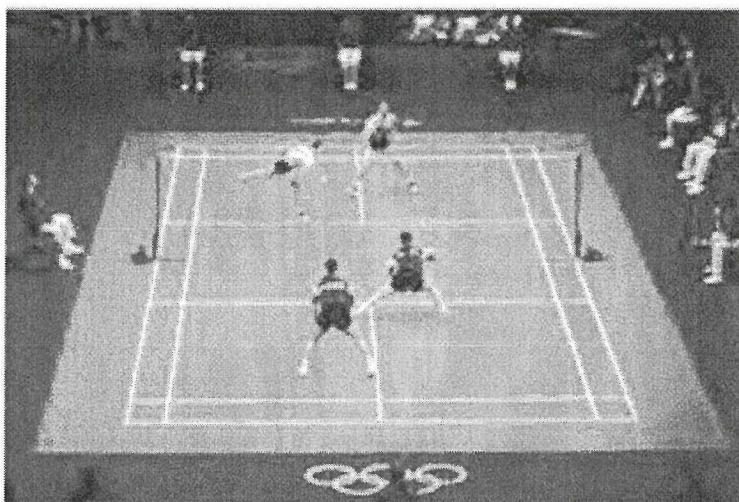

At a particular point in a badminton match, the shuttlecock is at a height of 2.45 m when a player, who is 5.70 m from the net, hits it horizontally at a speed of  $25.0 \text{ ms}^{-1}$  so that it clears the net.

**Assume the absence of air resistance in the following calculations.**

- a) Verify that the time taken for the shuttlecock to hit the ground is approximately 0.70 seconds.

**[3 marks]**

- b) Does the shuttlecock land in court or out of court? Justify your answer with an appropriate calculation.

**[3 marks]**

- c) Air resistance will increase the time of flight of the shuttlecock to considerably more than 0.70 seconds. Explain **why** air resistance increases the time of flight of the shuttlecock.

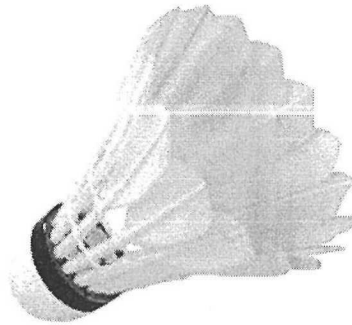

---

---

---

---

---

---

---

---

[3 marks]

- d) The height of the badminton net is 1.52 m. The shuttlecock is again hit horizontally at  $25.0 \text{ ms}^{-1}$  by a player 5.70 m from the net. If air resistance causes the shuttlecock to have a **vertical** acceleration of  $4.9 \text{ ms}^{-2}$  downwards, but has no horizontal effect, and the shuttlecock takes 0.20 seconds to reach the net, will it clear the net?

[5 marks]

**Question 23**

Archeologists have recently discovered the jawbone of a prehistoric animal. They reconstruct the bone in an attempt to determine the eating habits of the animal.

Below is a diagram of the reconstructed fossil together with a force diagram for the jaw.

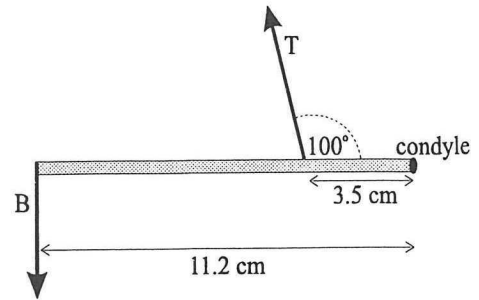
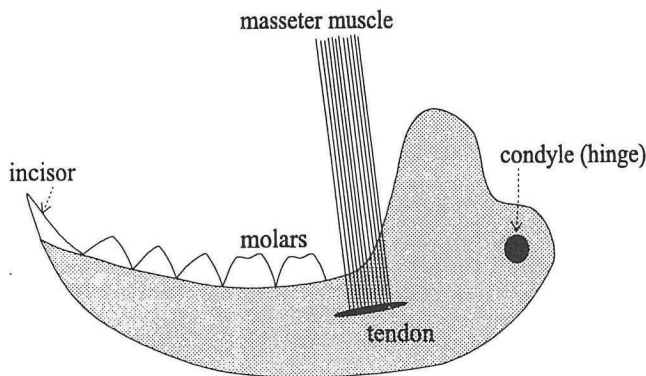

$T$  = the tension in the masseter muscle.  
 $B$  = the bite force possible by incisors when  $T$  is applied.

- a) Calculate the tension required in the masseter muscle if the archeologists estimate the animal needed to exert a maximum incisor bite force of 900 N on each side of the jaw with the masseter muscle at an angle of  $110^\circ$ .

[4 marks]

- b) The archeologists changed the angle between the masseter muscle ( $T$ ) and the jawbone to  $90^\circ$ . What effect would this have on the maximum possible bite force ( $B$ )?

No calculations are required but you must justify your answer.

[3 marks]

- c) From your answer to a), calculate the cross-sectional area of the tendon used to hold the masseter muscle to the jawbone if the tendon has a breaking stress of  $6.0 \times 10^7 \text{ Nm}^{-2}$ .

$$\text{Breaking Stress} = \frac{\text{Force}}{\text{Area}}$$

[2 marks]

**Question 24**

A power station transmits 300 MW of electrical power at a voltage of 220 kV. The diagram below shows how this power is transferred.

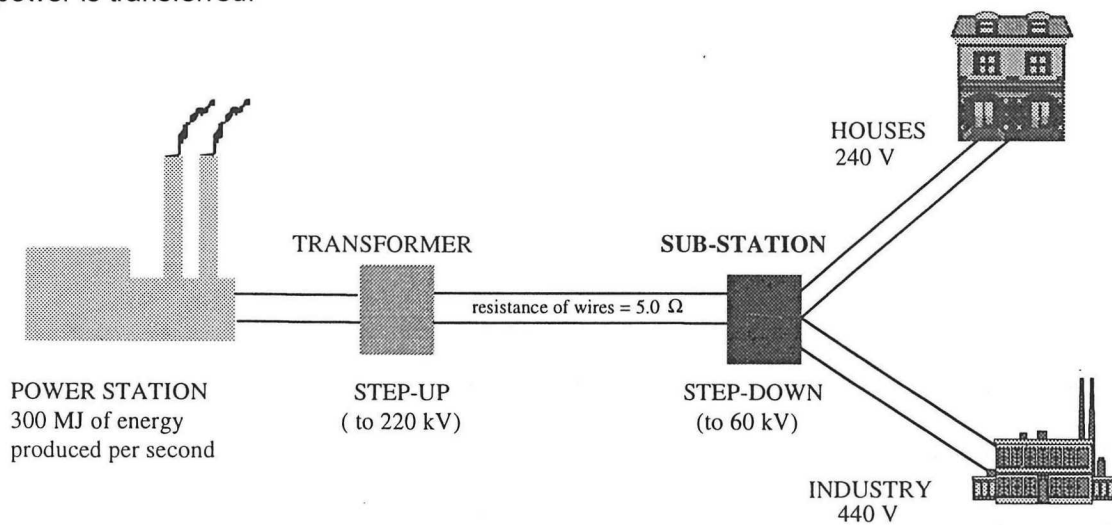

- a) When the power is transmitted over large distances, thick inexpensive wires are used to transmit the energy at high voltages. Why are **thick** wires used?

[2 marks]

- b) Calculate the **drop in voltage** between the transformer and the sub-station shown in the diagram.

[3 marks]

- c) How many joules of energy are **wasted** each year by the power system as it transmits electrical energy between the transformer and the sub-station?

[4 marks]

The following questions refer to the **step-down transformer** located at the sub-station.

- d) If the secondary coil has 150 turns, how many turns does the primary coil have?

[If you were unable to determine an answer to part b) above, assume the primary voltage for the transformer is 210 kV]

[3 marks]



- e) If the transformer operates at 88 % efficiency, what current is delivered from the secondary coil of the transformer?

**[4 marks]**

- f) One of the main causes of the loss of energy in a transformer arises from Eddy currents in the core of the transformer. How are Eddy currents created and what can be done to minimize their effect?

**[4 marks]**

**End of Section Two**

**SECTION THREE:** (Comprehension and Data Analysis – 40 marks or 20 % of total for paper)

There are **two** questions in this section. Answer both questions in the spaces provided.

**Question 25****Data Analysis – Vibrating Wires**

The photograph below shows a sonometer. A metal wire (similar to a guitar string) is held taut on the sonometer by suspended masses. The wire vibrates when it is plucked.

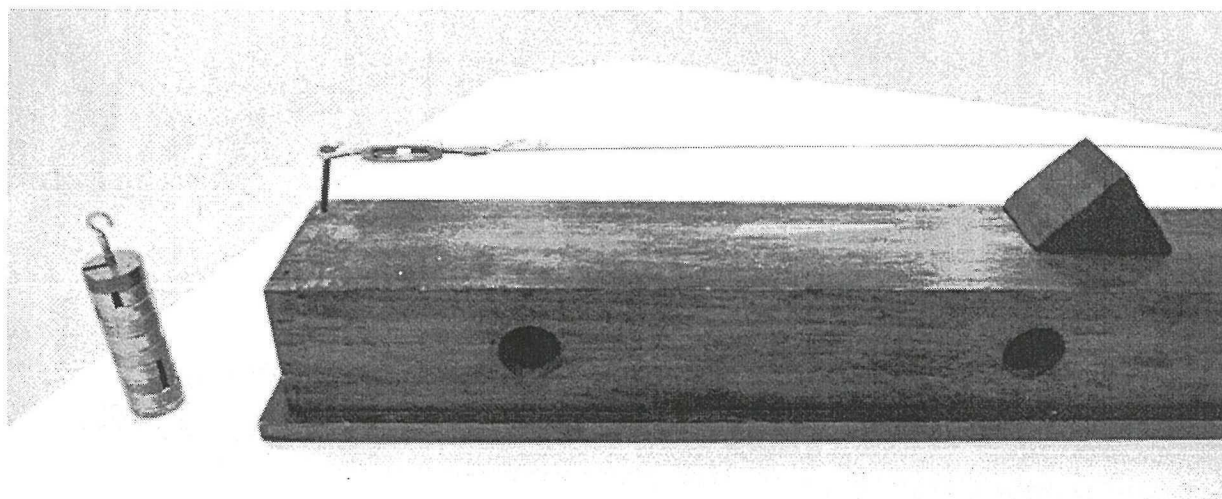

Students conducted an experiment, using a sonometer. Increasing the mass that is suspended from one end of the wire varies the tension in the wire. The lowest frequency of the vibrating wire is measured (in Hz) using an appropriate app on a smartphone, as shown in the photograph below.

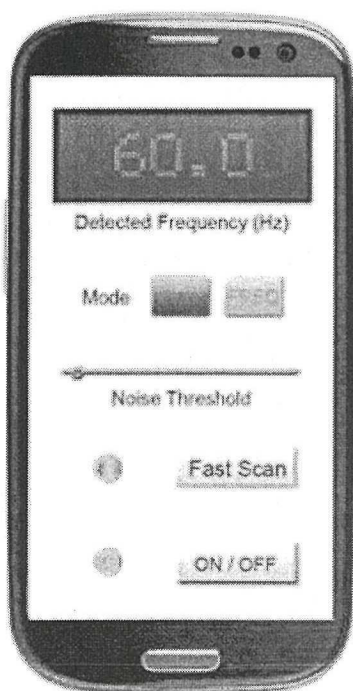

The length of the wire is held constant at  $L = 0.325$  m during the experiment.

Research by the students before conducting the experiment revealed the expected relationship between the frequency  $f$  (in Hz) and the mass  $m$  (in kg) to be given by the formula given below.

$$f^2 = \frac{mg}{4\rho L^2}$$

Where  $\rho$  is the linear density of the wire (in  $\text{kg m}^{-1}$ ) and  $g$  is the acceleration due to gravity.

The data collected by the students is shown in the table below.

Mass attached to wire (kg)	Frequency $f$ (Hz)	(Frequency) <sup>2</sup> $f^2$ ( $\text{Hz}^2$ )
0.50	197	$3.88 \times 10^4$
0.75	211	
1.00	263	
1.25	291	
1.50	314	

The error in measuring the mass is  $\pm 0.05$  kg.

- a) Complete the information for the **frequency squared** ( $f^2$ ) in the data table. Be careful to record values to the appropriate precision.

[2 marks]

- b) Plot a graph of  $f^2$  (on y-axis) against  $m$  (on x-axis). Use the graph paper provided.

**Show the error bars and draw a line of best fit.**

[4 marks]

- c) Determine the gradient of your line of best fit. Include the appropriate units.

[3 marks]

- d) Use the **gradient of your line of best fit** and the relationship given in the background information to find the magnitude of  $\rho$ , the linear density of the wire. **Give the value to 3 significant figures.**

[4 marks]

- e) What are two important variables which were controlled during this experiment?

Variable 1	
Variable 2	

[2 marks]

- f) Suggest one way of improving the experiment. Explain how your suggestion would improve the experiment.

[1 mark]

- g) In this investigation it is assumed that the wire vibrated in its fundamental mode of vibration. Draw a labelled diagram to show the **third harmonic** for the vibrating wire.

[2 marks]



- h) The app for the frequency claims to have **relative error** of only 2 %. What is the **absolute error** for each of the frequencies measured? Use the  $\pm$  notation and give the value to one decimal place.

Frequency (Hz)	Error (Hz)
197	$\pm 3.9$
211	
263	
291	
314	

[2 marks]

See next page

Question 26

Using Mass Spectrometry to Identify Drug Cheats in Sport

Many sporting organizations are faced with the real prospect that many of their athletes use a variety of performance enhancing drugs. To discourage such activities the authorities conduct regular random drug tests. This involves taking urine or a blood samples from the athlete and subjecting the sample to analysis.

One of the favoured methods of analyzing the sample is to use a technique known as mass spectrometry or MS for short. The samples taken from the athletes are broken down into very tiny parts within a vapour. The vapour is then ionized into charged particles (known as “ions”) and then accelerated to a high speed by a powerful electric field.

After accelerating to high speeds, the ions enter a chamber where there is a uniform magnetic field. The ions experience a force due to the magnetic field and move in a curved path towards a detector. The images created on the detector are unique for the various charged fragments and hence they act like a “fingerprint” for the various substances involved.

By comparing the image obtained from the MS machine with the many known images for the banned substances it is possible to identify the presence of an illicit substance in the sample taken from the athlete. In this case, authorities will say that the athlete has returned a “positive test result” and punitive action may result.

The diagram below shows the principle of the mass spectrometer.

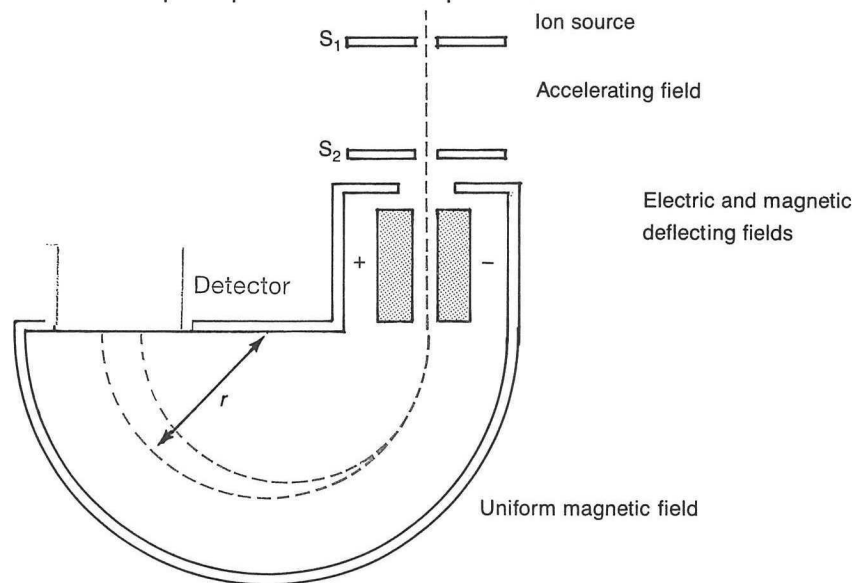

a) Why must the molecules in the vapour be ionized before entering the mass spectrometer?

[2 marks]

- b) What is the **direction** of the magnetic field if the beam of charged particles is to bend in the direction shown in the diagram?

[2 marks]

- c) The magnetic field provides the centripetal force that causes the charged particles to follow a curved path within the uniform magnetic field.

Prove that the following relationship is correct.

$$\frac{m}{q} = \frac{Br}{v}$$

[3 marks]

- d) A particular ion (X) has a charge of +1 and a relative mass of 23. Another ion (Y) has a charge of +1 and a relative mass of 39. Both ions move at the same velocity in the same magnetic field. Determine the ratio of the radii of the curved paths taken by these ions.

[3 marks]

- e) Ions with a mass of  $6.80 \times 10^{-27}$  kg are accelerated through the electric field section of the mass spectrometer and emerge with kinetic energy of 4.24 eV. What is the velocity of these ions?

[3 marks]

To ensure that all ions that enter the magnetic field chamber of the mass spectrometer have the same velocity it is necessary to first pass the mixture of ions through a device known as a “velocity selector”. This device consists of a pair of crossed fields – that is, a magnetic field and an electric field that are at right angles to each other. These two fields are arranged in such a way that ions which have a specific velocity will pass through the region of the crossed fields without any deflection.

This is shown in the diagram below.

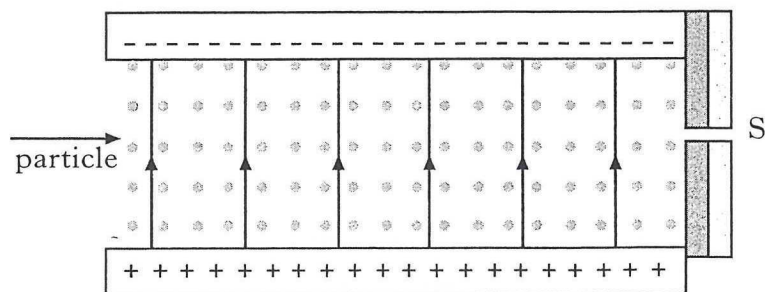

- f) If the ions from part e) are passed through the crossed fields without deflection and the magnetic field used has a strength of 1.365 T, what is the strength of the electric field used?

[If you were unable to determine an answer to part e) above, use a speed of  $1.50 \times 10^4$  ms<sup>-1</sup> in this question]

[3 marks]



- g) The electric field used in the crossed fields is provided by a set of parallel oppositely charged plates that are separated by a distance of 8.00 mm. Calculate the magnitude of the potential difference between the plates.

[2 marks]

- h) An ion moving in a uniform electric field will experience an electrical force that will increase the energy of the ion. However, the same ion moving in a uniform magnetic field will not experience a change in its energy even though a magnetic force acts on it.

Why does this difference in behavior occur?

[2 marks]

**End of Examination**





